



BERGSLI

Hantek AS

Crane Slung Drum Rotator

(DTR 3 & 4 Series)

Crane Slung Drum Rotators are designed for controlled manual rotation of 210 litre drums, the attachment is slung under a crane, small fork pockets are fitted for use with a forklift truck. The gearbox allows controlled pouring and rotation through a full 360 degrees. Variations in models allows for either crank handle or loop chain operation.

The Crane Slung Drum Rotator is designed to offer controlled pouring and transport of drums. In order to pick up a drum, set the girdle to its horizontal position by using the handle or chain fitted to the geared turning box./gearbox. The lifting yoke must then be positioned at a height such that the girdle fits between the drums centre most rolling hoops. Once securely fastened the drum can be lifted to pouring height and rotation can commence again by means of the handle or chain fitted to the gearbox. The gearbox will lock the drum at any angle during tipping.

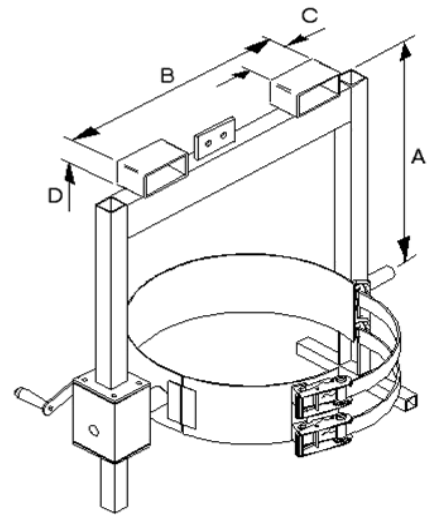

Model Ref	Capacity	Drum Type	Method of Rotation	A Free Height	B Fork Spread	C Fork Width	D Fork Thickness
DTR-3-DS	360kgs	1 & 2	Crank Handle	818mm	707mm	140mm	60mm
DTR-4-DS	360kgs	1 & 2	Loop Chain	818mm	707mm	140mm	60mm



BERGSLI Hantek AS

Postadresse: Postboks 2553 Kjørbeek, 3702 Skien, Norway | Besøksadresse: Bedriftsveien 64, 3735 Skien, Norway

Telefon: 3550 3550 | Web: www.hantek-as.no