

Fork Mounted Drum Rotator (DTR)

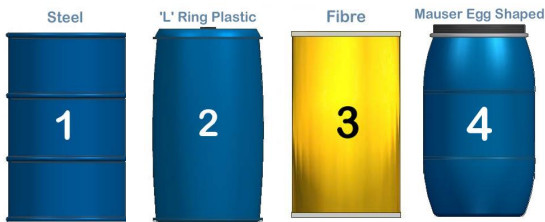

Fork Mounted Drum Rotators are designed for manual rotation of 210 litre drums. The attachment simply slides onto the truck forks, thus allowing 360 degree controlled pouring/rotation via the gearbox. Variations of girdle types are available to suit steel or plastic drums; there is also a model to suit smaller 110 litre drums

The Fork Mounted Drum Rotator offers controlled, safe pouring of 210litre steel/plastic drums. In order to pick up a drum; set the girdle to its horizontal position by using the handle/chain loop fitted to the gearbox. The truck forks must then be positioned at a height such that the girdle fits around the centre of the drum, between its rolling hoops.. Ensure that the drum is held securely before lifting. Once lifted the drum can be rotated to begin pouring, the gearbox design ensures the drum can be locked at any desired angle.



Model Ref.	Weight	C of G
DTR-1-SC	90kgs	510mm
DTR-2-SC	96kgs	510mm
DTR-1-DS	92kgs	510mm
DTR-2-DS	98kgs	510mm
DTR-1-110	84kgs	310mm
DTR-2-110	90kgs	310mm

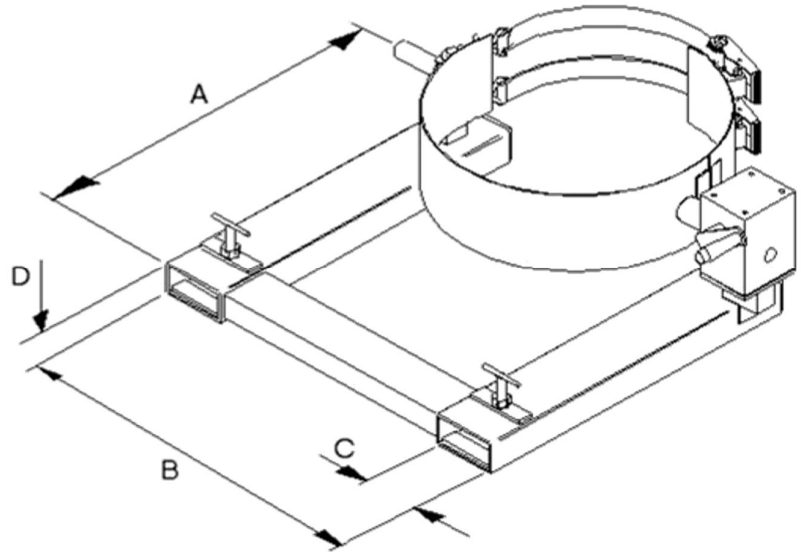

Hydraulic Gearbox Options Available – DTR-1-DSH/DTR-1-SCH

Model Ref.	Capacity	No. Of Drums	Type of Operation	Drum Types	"A" Load Ctr	"B" Fork Spread	"C" Fork Width	"D" Fork Thickness
DTR-1-SC	360kgs	1	Crank Handle	1	750mm	942mm	140mm	50mm
DTR-2-SC	360kgs	1	Loop Chain	1	750mm	942mm	140mm	50mm
DTR-1-DS	360kgs	1	Crank Handle	1 & 2	750mm	942mm	140mm	50mm
DTR-2-DS	360kgs	1	Loop Chain	1 & 2	750mm	942mm	140mm	50mm
DTR-1-110	200kgs	1	Crank Handle	1	750mm	751mm	140mm	50mm
DTR-2-110	200kgs	1	Loop Chain	1	750mm	751mm	140mm	50mm